

**RoHS COMPLIANT**

DESCRIPTION CONTROL

| REV | DESC          | DATE       | APP |
|-----|---------------|------------|-----|
| A   | FIRST RELEASE | 2016/08/12 |     |

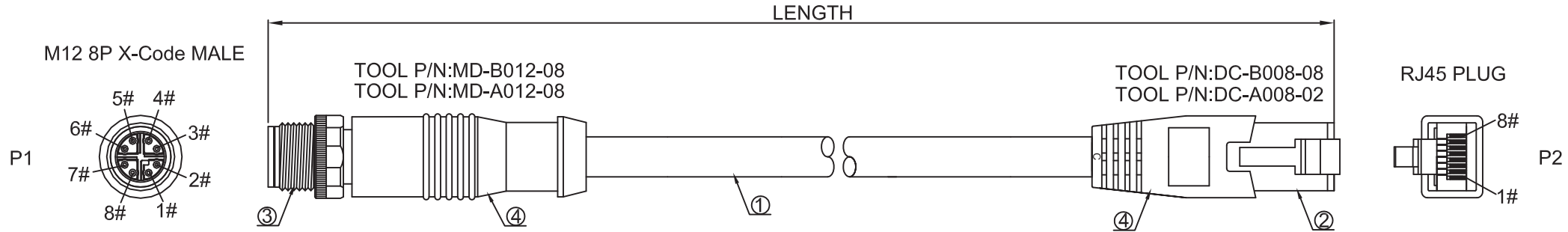

| PART NO.     | LENGTH  |
|--------------|---------|
| SE-S-0466-1M | 1000±30 |
| SE-S-0466-2M | 2000±30 |
| SE-S-0466-3M | 3000±30 |
| SE-S-0625-5M | 5000±50 |

**NOTES:**  
 1. PIN ASSIGNMENT SEE TO WIRE LIST.  
 2. ELECTRICAL TEST CONDITION:  
 (a).100%OPEN,SHORT & MISWIRE TEST,  
 (b). INSULATOR RESISTANCE:20 Mohm MIN.  
 DC 300V 0.03Sec.  
 (c). CONTACT RESISTANCE:3ohm MAX.

| ITEM | QTY | PART NUMBER | DESCRIPTION  |
|------|-----|-------------|--|
| 4    |     | G0001       | ALL CONNECTORS OVERMOLD BLACK PVC .                                    |
| 3    | 1   | A0825       | M12 8P X-Code MALE BLACK INSULATOR SOLDER TYPE.                        |
| 2    | 1   | A0650       | RJ45 8P8C PLUG,WITH SHELL,CAT6.  |
| 1    | 1   | E0762       | SSTP CAT. 6 (26AWG*1PAIR+AM)*4PCS+BRAID OD:6.2MM BLACK PVC JACKET .CSA |

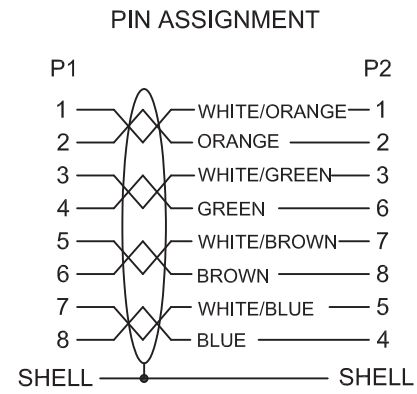

**Seconn International Enterprise Co., Ltd.**

|                      |           |                   |
|----------------------|-----------|-------------------|
|                      | REV. A    | DWG NO: SE-S-0466 |
|                      | CUSTOMER: |                   |
| DRAW,BY: DENG ZHIFEI |           | CUSTOMER P/N:     |
| CHECK,BY:            | SCALE     | UNIT              |
| APP,BY:              | FREE      | mm                |
|                      |           | SHEET 1/1         |