

RoHS COMPLIANT

DESCRIPTION CONTROL			
REV	DESC	DATE	APP
A	FIRST RELEASE	2015/06/23	

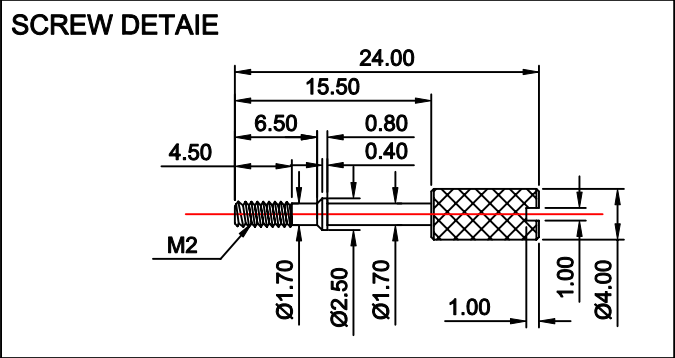

PIN ASSIGNMENT

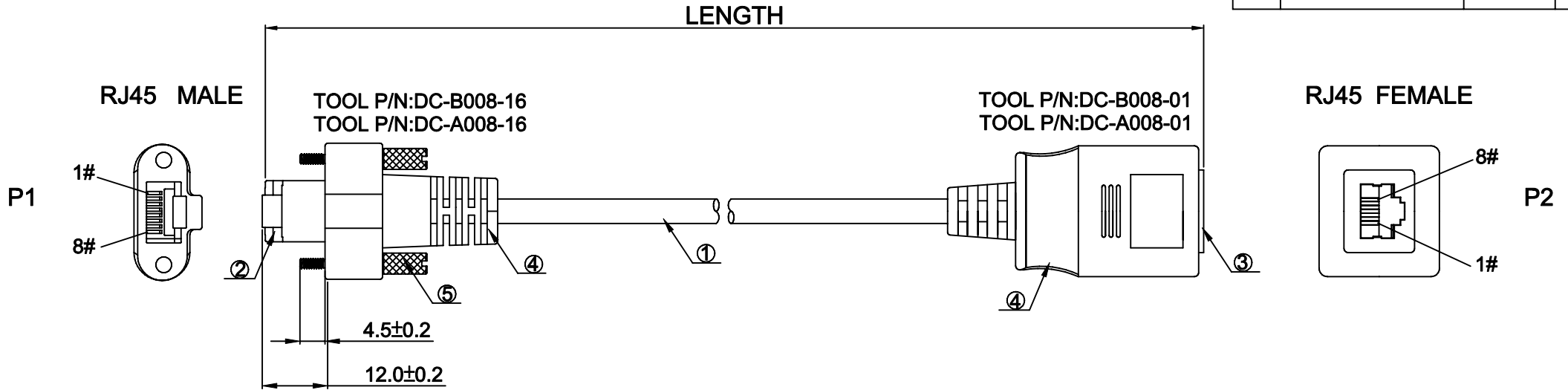
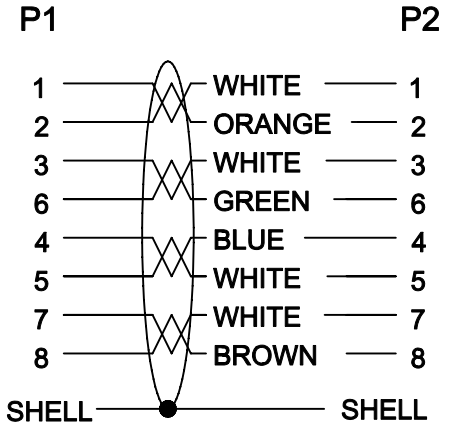

NOTES:

- PIN ASSIGNMENT SEE TO WIRE LIST.
- ELECTRICAL TEST CONDITION:
 - 100% OPEN, SHORT & MISWIRE TEST,
 - INSULATOR RESISTANCE: 20 Mohm MIN. DC 300V 0.01Sec.
 - CONTACT RESISTANCE: 3ohm MAX.

ITEM	QTY	PART NUMBER	DESCRIPTION
5		G0001	ALL CONNECTORS OVERMOLD BLACK PVC.
4	2	C0332	SCREW: M2 4.0*24.MM NICKEL PLANTED.
3	1	A0145	RJ45 FEMALE, BLACK INSULATOR SOLDER TAPE.
2	1	A0650	RJ45 8P8C PLUG, WITH SHELL, CAT6. (#TC6H6-23E)
1	1	E0762	(26AWG*1PAIR+A+M)*4+BRAID, OD:6.2MM, BLACK PVC JACKET SSTP CAT.6 CSA.

UNIT	mm	Projection			Secon International Enterprise Co., Ltd.		
DRAWN	<i>LI DONGFU</i>	SCALE	FREE	TITLE			
CHECK, BY		REV	A	RJ45 M/RJ45 F			
APP, BY		DATE	2015/06/23	TOLERANCES			
DWG NO.	SE-S-0213			X. = ±	.X = ±	.XX = ±	.XXX = ±
PART NO.		SHEET	1/1	SIZE	A4		