

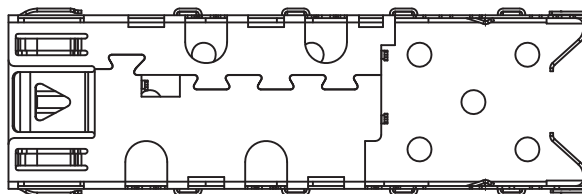

RoHS

THIS IS A RoHS  
COMPLIANT  
COMPONENT/  
PRODUCT.

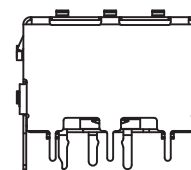
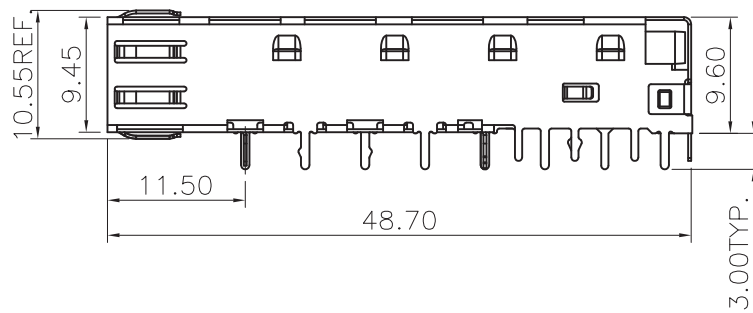
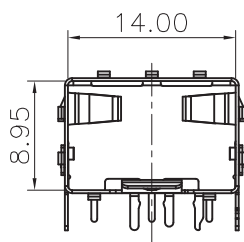
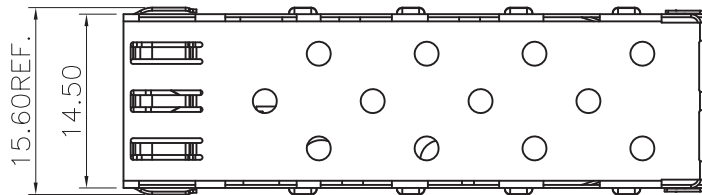

NOTES:  
1.MATERIAL:  
COPPER ALLOY THICKNESS:0.25mm

**Se** Seconn International Enterprise Co., Ltd.

TOLERANCES			PROJECTION	TITLE			
x.	= ±	----	 UNIT mm	SFP Cage 1x1 Dip Type			
x.x	= ±	0.30					
x.xx	= ±	0.20					
x.xxx	= ±	0.15	Angle ± 2.0°				
DRAWN	SIN	DATE	2015/10/13	PART NO.	SFP1-S9220T-02G		
SCALE	1:1	SIZE	A3	SHEET	1/2	REV	A

RoHS

THIS IS A RoHS COMPLIANT COMPONENT/PRODUCT.

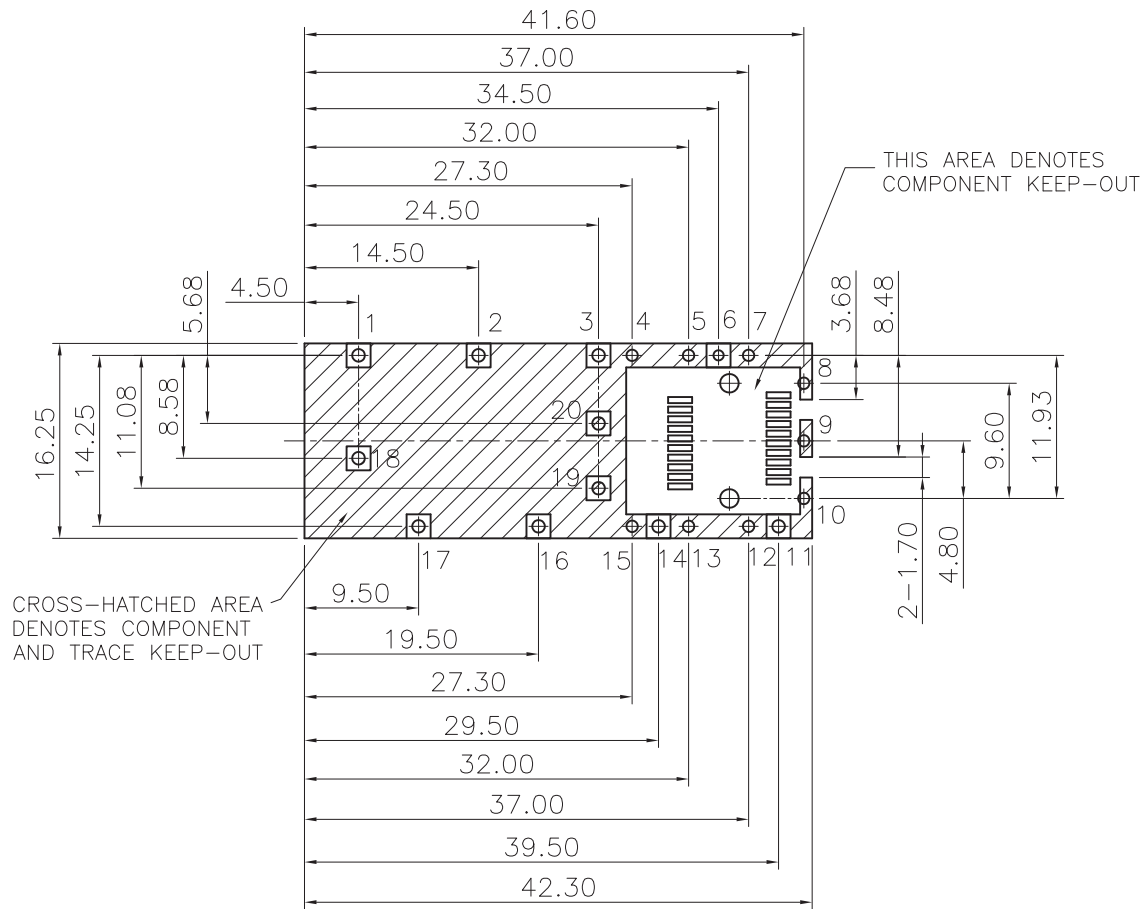

1. RECOMMENDED PCB THICKNESS:2.36  
(MINIMUM PCB THICKNESS:1.57)  
(ALL TOLERANCES ARE  $\pm 0.05$ )

1,2,3,11,14,16,17,18,19,20#孔直径为1.05mm;  
4,5,7,8,9,10,12,13,15#孔直径为0.95mm;  
6#孔直径为0.85mm;

		<b>Seconn International Enterprise Co., Ltd.</b>					
		TOLERANCES		PROJECTION	TITLE		
x. = $\pm$ ---- x.x = $\pm 0.30$ x.xx = $\pm 0.20$ x.xxx = $\pm 0.15$			<b>SFP Cage 1x1 Dip Type</b>				Angle $\pm 2.0^\circ$
UNIT mm							
DRAWN	SIN	DATE	2015/10/13	PART NO.	SFP1-S9220T-02G		
SCALE	1:1	SIZE	A3	SHEET	2/2	REV	A